



INVENTIVE SIMPLIFICATION

Project _____

Item _____

Quantity _____

Date _____

XEEC-1011-EPL

XEEC-1011-EPL

MODEL
EVEREO 600

- | | |
|--------------------------|--|
| • Food preserver | • Hinged Right (Left Hand Door) |
| • Electric | • 7" Touch control panel |
| • 10 Trays GN 1/1 | |



DESCRIPTION

Service Temperature Food Preserving is a patented technology that has been designed to preserve food at the temperature at which it is served and eaten. It means that you can cook food, keep it hot without blast freezing and regenerating it, and serve it in a few seconds at any time of the day and with zero waiting time for your customers.

With only 600 mm deep, the **EVEREO® 600** is the compact solution for quick installations in small spaces and outside the kitchen area.

The **EVEREO® 600** easily fits any business and is available with left or right door opening. The wide glass and the LED light allow maximum visibility of the products while the compact size allows you to quickly identify the products to be served without taking out the trays.

STANDARD TECHNOLOGY

AIR DISTRIBUTION IN THE PRESERVING CHAMBER:

- AIR.Maxi™ technology: airflow speed management intelligently redistributed.

TEMPERATURE CONTROL:

- Latest generation sensors allow to set up EVEREO with a certainty of a degree of precision of 0.5 ° C

THERMAL INSULATION AND SAFETY

- Protek.SAFE™ technology: maximum thermal efficiency and working safety (complies with the IEC/EN60335-2-42 rule).
- Protek.SAFE™ technology: fan impeller brake to contain energy loss at door opening.
- Protek.SAFE™ technology: electrical power absorption related to the real needs.
- Protek.SAFE™ PLUS: double glazed door.

DOUBLE STACK COLUMN:

- MAXI.Link technology: allows double-stack EVEREO columns to be created.

STANDARD TECHNICAL FEATURES

- Rounded stainless steel AISI 304 cavity for hygiene and ease of cleaning.
- Cavity lighting through external LED lights.
- Light weight - heavy duty structure using innovative materials.
- Contactless contact latch.
- Self-diagnosis system for detecting problems or failures.
- Safety temperature limiter.
- Stainless steel C-shaped rackrails

APP & WEB SERVICES

- Marketplace EXEVER

STANDARD PRESERVING FEATURES

SETTINGS:

- **TEMPERATURE:** 58°C(136,4°F) - 75°C(167°F).
- **AUTOMATIC PROGRAM SET:** possibility to select the food to be preserved in the pre-loaded program list and automatically regeneration time, preserving temperature and time will be set up for you.
- **TRAY ASSIGNMENT:** Possibility to assign one preserving program to a dedicated tray.
- **MULTI.TIME LIST:** technology to manage up to **06 timers** to preserve different products at the same time.
- **ROP:** Manage the programs Reorder Point (the minimum number of sous-vide single portions that must always be present in your chamber) in order to not run out during service of your best selling menu items.
- **CLIMA.Control:** Humidity or dry air set by 10%.

PROGRAMS:

- Store up to **256 users programs**.
- **PRESERVING MODE:** choose or set the program that is more suitable to preserve your food for days or weeks in sealed containers.
- **HOLDING MODE:** set your personal programs while using open containers or trays, and have your food held at the precise temperature.
- **MARKETPLACE MODE:** you you will be able to use the programs to be used with the food that you have ordered by any of our EXEVER Approved vendors.

We reserve the right to make technical improvements - March: 2018

XEEC-1011-EPL

Views
Connection positions
Dimensions and Weights

XEEC-1011-EPL

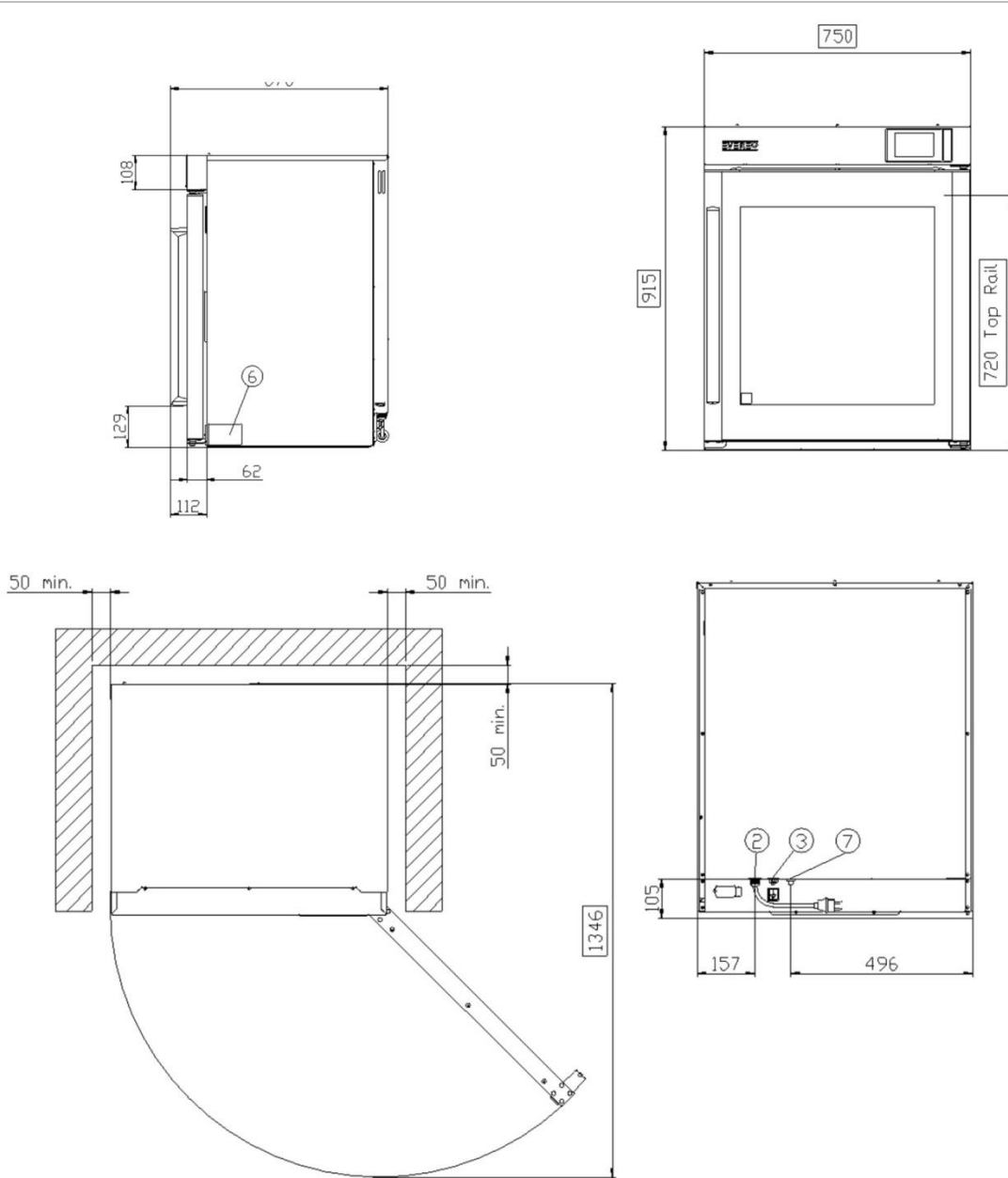

DIMENSIONS AND WEIGHT

Width	750 mm
Depth	678 mm
Height	915 mm
Net Weight	95 Kg
Pan Spacing	67 mm

CONNECTION POSITIONS

1	Terminal board cover box
2	Terminal board power supply
3	Unipotential terminal
6	Technical data plate
7	Safety thermostat
8	3/4 " Thread water inlet
10	Rotor.KLEAN connection
11	Cavity drain pipe
12	Hot fumes exhaust chimney
13	Accessories connection
27	Cooling air outlet



INVENTIVE SIMPLIFICATION

XEEC-1011-EPL

Power supply
Water connections
Installation requirements
Accessories

XEEC-1011-EPL

POWER SUPPLY

STANDARD	
Voltage	220-240 V
Phase	1PH+N
Cycle	50-60 Hz
Total power	3.2 kW
Maximum Amp Draw	14 A
Required breaker size *	16 A
Power cable requirement	H07RN-F 3G 1.5 mm ²
Cord diameter	10 mm
Plug	schuko

OPTION B eliminare	
Voltage	220-240 V
Phase	1PH+N+PE
Cycle	50-60 Hz
Total power	5.15 kW
Maximum Amp Draw	22.5 A
Required breaker size *	32 A
Power cable requirement	H07RN-F 3G 4 mm ²
Cord diameter	13,96 mm
Plug	NOT INCLUDED
* Recommended size - observe local ordinances	

INSTALLATION REQUIREMENTS

Installations must conform to all local electrical systems, specifically minimum wire gauge required for field connection, hydraulic and ventilation codes.

ACCESSORIES

- **PRESERVING ESSENTIALS:** Special trays.
- **FLOOR STAND**
- **HIGH STAND**
- **FEET KIT**
- **Wi-Fi** Connection board to keep the oven connected to UNOX cloud mandatory to extend warranty.
- Available in different voltage.
- **SPRAY & RINSE:** detergent with natural ingredient.

Register to access data and product specifications
infonet.unox.com

